



3301 1"
NEW



TOP VIEW
SIDE VIEW

HEIGHT	1 3/8 IN	3.5 CM
WIDTH	1 3/8 IN	3.5 CM
THICK	7/8 IN	2.2 CM
WEIGHT	0.1 LBS	0.05 KGS

3315 1 1/2"
NEW
INQUIRY



TOP VIEW
SIDE VIEW

HEIGHT	1 3/4 IN	4.5 CM
WIDTH	1 3/4 IN	4.5 CM
THICK	3/4 IN	1.9 CM
WEIGHT	0.1 LBS	0.08 KGS

3302 2"
NEW



TOP VIEW
SIDE VIEW

HEIGHT	2 3/8 IN	6.0 CM
WIDTH	2 3/8 IN	6.0 CM
THICK	1 IN	2.5 CM
WEIGHT	0.2 LBS	0.1 KGS

3325 2 1/2"
NEW

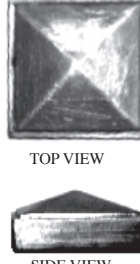

TOP VIEW
SIDE VIEW

HEIGHT	3 IN	7.6 CM
WIDTH	3 IN	7.6 CM
THICK	1 IN	2.5 CM
WEIGHT	0.3 LBS	0.1 KGS

3303 3"
NEW



TOP VIEW
SIDE VIEW

HEIGHT	3 IN	7.6 CM
WIDTH	3 IN	7.6 CM
THICK	1 1/4 IN	3.2 CM
WEIGHT	0.3 LBS	0.1 KGS

7744 3 1/2"
NEW

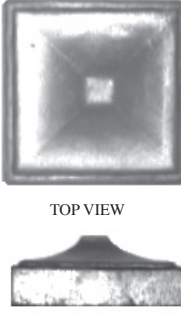

TOP VIEW
SIDE VIEW

HEIGHT	3 7/8 IN	9.8 CM
WIDTH	3 7/8 IN	9.8 CM
THICK	1 1/2 IN	3.8 CM
WEIGHT	0.2 LBS	0.1 KGS

3304 4"
NEW
INQUIRY- NOT TO SCALE



TOP VIEW
SIDE VIEW

HEIGHT	4 1/2 IN	11.4 CM
WIDTH	4 1/2 IN	11.4 CM
THICK	1 1/2 IN	3.8 CM
WEIGHT	0.5 LBS	0.2 KGS

9286 2 1/2 x 5 1/4"
NEW

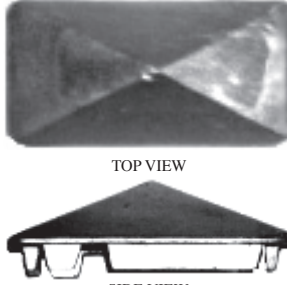

TOP VIEW
SIDE VIEW

STUB IS 1/2 INCH LONG BY 2 1/2 INCH BY 5 1/4 INCHES. SEAT IS 6 INCHES BY 3 1/8 INCHES.

HEIGHT	6 IN	15.2 CM
WIDTH	3 1/8 IN	7.9 CM
THICK	2 1/8 IN	4.5 CM
WEIGHT	0.8 LBS	0.4 KGS

130 **DF**
FLAT HAND RAIL BRACKET

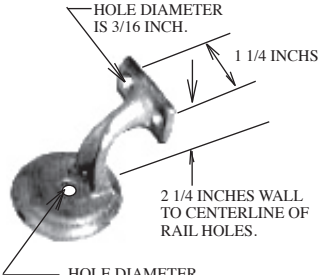

HOLE DIAMETER IS 3/16 INCH.
1 1/4 INCHES
2 1/4 INCHES WALL TO CENTERLINE OF RAIL HOLES.
HOLE DIAMETER IS 5/16 INCH.
SCALE: 1 INCH = 3 INCHES

HEIGHT	3 IN	7.6 CM
WIDTH	2 3/8 IN	6.0 CM
THICK	2 7/8 IN	7.3 CM
WEIGHT	0.2 LBS	0.1 KGS

131 **DF**
CURVED HAND RAIL BRACKET

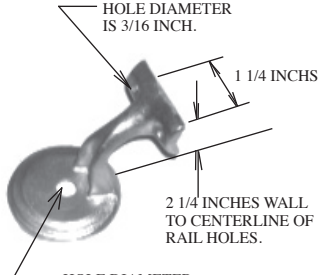

HOLE DIAMETER IS 3/16 INCH.
1 1/4 INCHES
2 1/4 INCHES WALL TO CENTERLINE OF RAIL HOLES.
HOLE DIAMETER IS 7/16 INCH.
SCALE: 1 INCH = 3 INCHES

HEIGHT	3 IN	7.6 CM
WIDTH	2 3/8 IN	6.0 CM
THICK	2 7/8 IN	7.3 CM
WEIGHT	0.2 LBS	0.1 KGS

8021 **DF**
OLD 21F
TOP RAIL, WALL MOUNTED

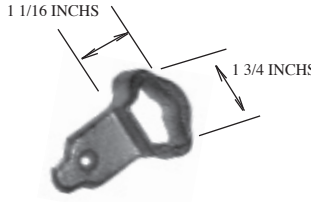

1 1/16 INCHES
1 3/4 INCHES
NOTE: SCALE IS 1 INCH = 6 INCHES

HEIGHT	3 5/8 IN	9.2 CM
WIDTH	2 1/4 IN	5.7 CM
THICK	1 IN	2.5 CM
WEIGHT	0.2 LBS	0.1 KGS

REVISION DATE: 12/29/94

ON MOST POST CAPS THE TUBE OR POST WILL WEDGE FIT INTO THE CAP AND ENTER APPROXIMATELY 5/8 OF AN INCH.

SCALE: 3 INCH = 1 FOOT UNLESS NOTED